

95-0257-0014S1

series: Accessories mechanical

Dimensions: L 1210, B 265, H 225
Colour: stainless steel

Telescope tripod Set: Telescope tripod Professional, Hmax 4,45m, Hmin 1,1m, stainless steel, air-cushioned, adjustable stands to compensate uneven terrain, with standard spigot 30 mm conforming to DIN 14640, bracing set, carrier box

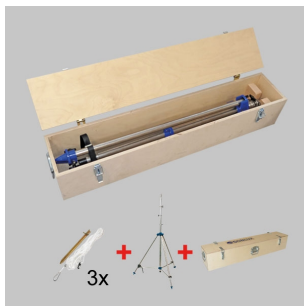

electro-technics:

Voltage

lamp 1:

Lifespan

weights and measures:

Length L	1.210 mm
Width B	265 mm
Height H	225 mm
Weight	25,14 kg